

Operating manual

Original operating manual



EVE!

Bathing and shower lift

Version 1.0/E

Subject to technical modifications

19 October 2017 11:48:51

Table of contents

1.	Imprint.....	4
1.1	Acknowledgment	4
1.2	Manufacturer's address	4
1.3	TÜV quality seal	4
2.	Introduction	5
2.1	Preface	5
2.2	Liability and warranty	5
3.	The operating manual.....	6
3.1	Validity	6
3.2	Type plate.....	6
3.3	Description.....	6
4.	Safety.....	7
4.1	Intended and appropriate use.....	7
4.2	Other prescriptions	7
4.3	Safety instructions	7
4.4	List of used safety instructions.....	8
4.5	Warnings	9
5.	Transport	11
5.1	Unpacking the product.....	11
5.1.1	Removing the cardboard.....	11
5.1.2	Loosening the product from the pallet.....	11
6.	Installation.....	12
6.1	Electrical connection.....	12
6.2	Electric motor/battery unit.....	12
7.	Operating elements and their function	13
7.1	Handset	14
7.1.1	Handset functions	14
7.2	The keypad with/without scale.....	15
7.2.1	Putting the scale into operation.....	15
7.2.2	Zeroing and taring the scale.....	16
7.3	The safety armrests.....	16
7.4	The safety belt	17
7.5	The control unit.....	18
7.5.1	Electrical emergency lowering system	18
7.5.2	The emergency stop switch	18

7.6	24V battery unit	19
7.7	External charging unit/Wall charging unit	19
7.8	Crash protection	20
7.9	Automatic crushing protection	20
8.	Operation	21
8.1	Prior to use	21
8.2	During use	21
8.2.1	Lifting the patient from a bed.....	21
8.2.2	Getting autonomously onto the seat lift.....	22
9.	Cleaning/Disinfection	23
9.1	Cleaning the EVE! bathing and shower lift	23
9.1.1	Cleaning the scale	23
9.2	Disinfecting the EVE! bathing and shower lift.....	23
9.3	Sterilizing the EVE! bathing and shower lift.....	24
10.	Checks/tests	25
10.1	Maintenance of the 24 Volt battery	25
11.	Waste disposal	26
11.1	Disposal of the packaging material.....	26
11.2	Disposal of the product.....	26
12.	Troubleshooting/After-sales service.....	27
12.1	Troubleshooting help	27
13.	Assembly/Disassembly	29
13.1	Replacing the castors	29
13.2	Replacing the handset.....	29
13.3	Replacing the battery.....	30
13.4	Replacing the control unit.....	30
13.5	Positioning the armrests	31
13.5.1	Setting the angle of the armrests	31
13.5.2	Disassembling the armrests.....	31
14.	Appendix.....	33
14.1	Technical data	33
14.2	Design drawing.....	35
14.3	Declaration of Conformity	37
14.4	Accessoires/Spare parts.....	38
14.5	Electromagnetic Compatibility	39
14.6	Journal.....	43

1. Imprint

1.1 Acknowledgment

Dear customer, we would like to express our sincere thanks for the trust you have placed in us by purchasing this BEKA Hospitec GmbH product. Our products are manufactured and tested according to stringent quality criteria.

1.2 Manufacturer's address

	<p>BEKA Hospitec GmbH Am Rübenmorgen 3 35582 Wetzlar Phone: +49(0)641-9 22 22-0 Fax: +49(0)641-9 22-22-20 info@beka-hospitec.de</p>
---	--

1.3 TÜV quality seal

	<p>BEKA Hospitec GmbH is certified according to DIN EN ISO 9001 and DIN EN ISO 13485 by TÜV SÜD Product Service GmbH. Therefore, the development, manufacturing, quality assurance and service of our entire product range is subject to high quality standards.</p>
--	---

2. Introduction

2.1 Preface

A correct use of the device is imperatively in order to ensure its proper and safe functioning. Please read the provided operating manual carefully and observe in particular the therein contained safety instructions.

The maintenance, inspection, assembly and installation as well as well as further technical interventions on the product must only be executed by BEKA Hospitec either by specialised companies authorised to this effect by BEKA Hospitec. The operation of the product as well as technical interventions on the product must only be carried out by specially trained personnel.

2.2 Liability and warranty

On the basis of the information contained in this manual, the publisher accepts no liability for damages resulting from improper, incorrect or inappropriate use of the product. The product must only be operated by persons, who are familiar with the manual and the product as well as the national regulations, laws and prescriptions related to work, safety and accident prevention.

The manufacturer of the product is only responsible for the safety and the reliability of the product, if regular functional tests and checks are conducted. Operate the product only with original accessories, otherwise the manufacturer's liability will expire.

In case of technical interventions, such as extensions and fittings to our products, which are not carried out by BEKA Hospitec either by a specialist company authorised by BEKA Hospitec, all warranty rights on the modifications as well as on the device or on the device function, which are related to the modification, shall expire.

For damages resulting from the use of spare parts and accessories, which are not authorized by the manufacturer, any further liability of the manufacturer shall be excluded.

Please note that there might be minor differences between the images and explanations contained in this manual and the actually supplied device. Subject to technical modifications and error.

The EVE! product is equipped with "B"-Type applied parts. All exposed, touchable, conductive parts are thereby considered as applied part.

3. The operating manual

3.1 Validity

This operating manual contains information, which is required for the operation and use of the product. In addition to the description of the equipment, the operating manual also includes a number of abstractions and exemplary illustrations. The equipment of the product therefore may differ in part from the descriptions and illustrations. Furthermore, please observe also the manuals with regard to the cleaning and the disinfection as well as the assembly and the disassembly of individual components of the product.

Please read the operating manual and the safety instructions before starting to use the product. Keep the operating manual near the device for future reference.

3.2 Type plate

		<p>This image shows the type plate. The type plate is located on the inside of the door of the bathing lift. The shown serial number (SN) 1617L62911 is only for exemplifying. In case of queries, please mention the serial number printed on the type plate of your stand-up and raising aid.</p> <p><i>Note: Note: because of legal regulations, it might be required that the article number and the serial number should be computer-readable as well and therefore they might be printed on the type plate in the form of a bar code as well.</i></p>
--	--	---

3.3 Description

In this manual, the product will be referred to as EVE!, bath and shower lift or EVE! bath and shower lift.

4. Safety

4.1 Intended and appropriate use

The product EVE! has been designed for lifting and transferring patients in hospitals, nursing homes and care centres. The product provides support during the bathing and showering process. The patient can be lifted from standing either reclined position. The bathing and shower lift EVE! is to be used exclusively for the indoor transport of patients on smooth and level floorings. The product may only be used for the specified purpose.

The product is designed for short-term use and must not come into contact with injured or damaged skin.

No side effects associated to a treatment are known. However, you must still respect and observe the safety instructions and the contraindications.

<p>WARNING</p> 	<p>Patients suffering from</p> <ul style="list-style-type: none"> ▪ Osteoporosis ▪ Spine disorders/spinal damage ▪ Osteogenesis imperfecta (brittle bone disease) ▪ Mental confusion ▪ Epileptic attacks <p>may only be treated with the EVE! bathing and shower lift following consultation with the attending physician.</p>
--	---

4.2 Other prescriptions

The product meets the current VDE-prescriptions 0100 and 0100-710. However, have a specialist company check the compliance of your electrical installation with the applicable prescriptions prior to operating and using the product. This requirement is only applicable for Germany. In other countries, other requirements might be applicable. Ask a qualified electrician to install the wall charging unit in accordance with the regulations applicable in your country.

4.3 Safety instructions

Please read the following safety instructions prior to using the product. All notes, specifications and warnings mentioned on the device as well as in the present operating manual must be imperatively respected and observed. The manufacturer BEKA Hospitec shall not accept any liability for any damages, failures or faults caused by improper operation or handling.

4.4 List of used safety instructions



Please observe the accompanying documents/operating manual.



Warning Hazardous Area.



Applied part "Type B" to DIN EN 60601-1.



Special waste, no household waste.
The device and the packaging materials never must be disposed of in the domestic waste stream.



CE-label in accordance with the EC-Directive on Medical Devices.



Solely intended for indoor use.



Protection class II.

4.5 Warnings

Note

- Protect the product against direct sunlight and heat.
- The equipment is not authorised for use in potentially explosive atmospheres.
- Never exceed the duty cycle or the maximum load.
- Make sure that the battery is charged in a well-ventilated room.
- The product must not be operated during the charging process of the battery.
- Only use propyl alcohol to clean the emergency lowering mechanism.
- When the door is opened, the battery and the control unit must not be exposed to permanent water jets.
- Never cover up, over sticker or change the slots and holes of the device.
- Do not push/pull the motor to operate the product and do not expose the product to lateral forces in any way whatsoever

Warning

- As soon as a patient has been installed on the EVE! lift, the brackets must be pivoted so as to surround the patient. The sling must be applied.
- Please check before and during the height adjustment procedure that your feet are not located in the area of the castors neither in the resident's area.
- Please make sure that no one grabs in the hazardous areas (bracket, carrier frame) during the adjustment procedure. *Risk of crushing.*
- Make sure that the patient cannot tilt forward or sideward when he/she is being lifted.
- Check the applied sling for visual damages prior to using it.
- Make sure that the patient is correctly positioned onto the bathing and shower lift and that the safety belt is locked.
- Please check that the hair, the arms and the legs of the patient are close to the body and cannot be squeezed.

Caution

- In case of unusual noises, damages or malfunctions, the product no longer must be used.
- Check prior to each use that all visible parts are intact. The product must not be used if any parts are damaged. Prior to each use of the device and its accessories, the user must check the functional safety and the good condition of the device and its accessories (visual check, functioning).
- The product must be disinfected after each treatment.
- Avoid slippery surfaces and thresholds.
- Do not use the EVE! bathing and shower lift over sloping or uneven floors.
- Supervision of the caregiver is required throughout the treatment.
- Check prior to each lifting operation whether the help of a second assistant is required.
- Each lifting and transport procedure must be adequately planned in order to ensure an optimal protection for the patient.
- Do not position yourself between the product and an obstacle during the transport procedure.
- Ensure that the patient seizes the handles provided to that effect with both hands.
- Do not lift the resident higher than is necessary.
- Engage the parking brakes of the wheelchair's castors to ensure a safe lifting and positioning of the patient. Leave the product's brakes engaged (activated).
- Keep the transport of the patient as short as possible
- Operate the product only with original accessories.
- Make sure that nothing is located in the direction of movement of the arm/hand rest when setting up the bathing and shower lift. *Risk of injury.*

5. Transport

5.1 Unpacking the product

To remove the packaging materials, you will need a cutter knife.

NOTE 	Take care not to damage the lift with the tools.
--	--

5.1.1 Removing the cardboard

Proceed in the following way to remove the cardboard:

- Cut the strap with the cutter knife
- Remove the strap
- Lift the cardboard up to remove it and put it aside

5.1.2 Loosening the product from the pallet

Both sides of the sling hoist are strapped to the pallet.

Proceed in the following way to loosen the product from the pallet:

- Unscrew the fixing screws of the straps
- Remove the straps
- Release the brakes of the wheels
- Remove the bubble wrap and the stretch film

After all fixations have been removed, you can lift the bathing and shower lift from the pallet (2 persons).

The accessories for your lift are included in the supplied cardboard box.

6. Installation

The EVE! bathing and shower lift is supplied ready for operation.

6.1 Electrical connection

The EVE! bathing and shower lift is equipped with a 24V-battery system. A VDE 0100 and 0100-710 compliant power connection is required for the charger cable as well as the wall charging unit. In operation, the EVE! bathing and shower lift is independent of the mains.

6.2 Electric motor/battery unit

The EVE! bathing and shower lift is equipped with a 24V electric motor. This motor is self-locking and therefore protected against unintentional lowering of the seat in case of malfunction or failure. The battery of the bathing and shower lift must be completely charged before starting to use the device.

Please check that the emergency stop switch is actuated. To actuate, close the door of the control box and the battery (cf. Chapter 7).

<p>NOTE</p> 	<p>The battery must be completely charged prior to the first use. The charging time is approx. 4 hours.</p>
---	---

7. Operating elements and their function

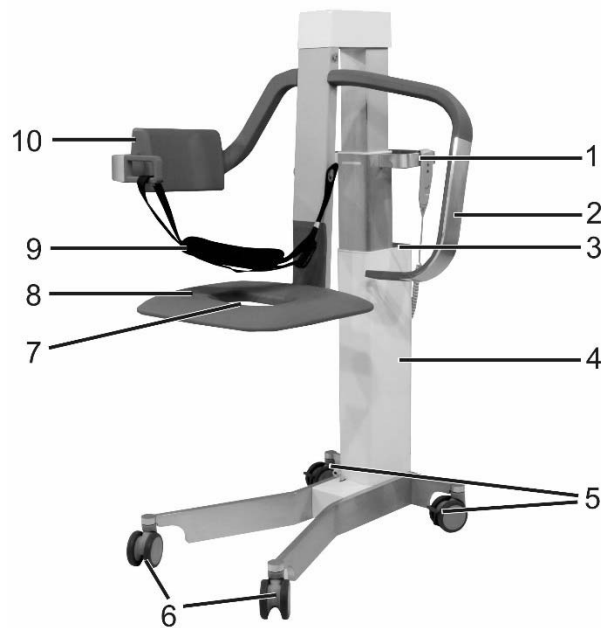

N°	Description	N°	Description
1	Grab handles	6	Front castors
2	Armrest	7	Hygiene opening
3	Scale display + control panel	8	Seat
4	Control box	9	Belt
5	Rear castors	10	Removable backrest

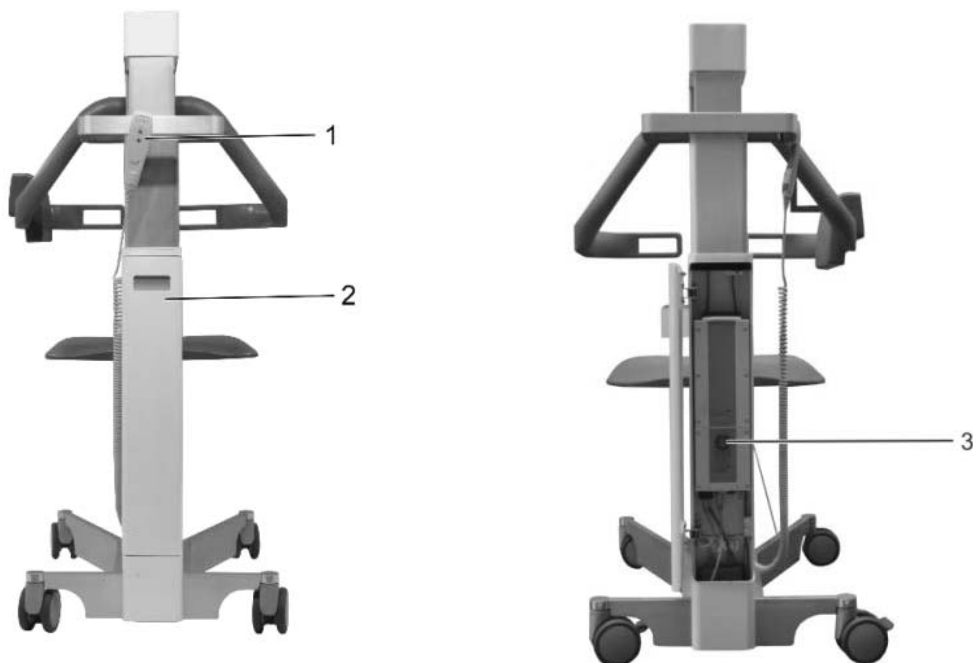

N°	Description
1	Handset
2	Door of control box and battery
3	Emergency stop button

7.1 Handset

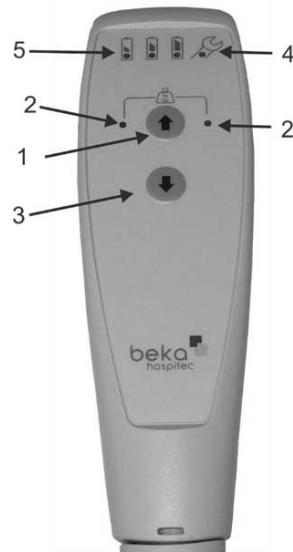

N°	Description	N°	Description
1	Raise seat	4	Service indication
2	Overload	5	Battery charge level indication
3	Lower seat		

7.1.1 Handset functions

Battery charge level indication

- If the *green* LED is illuminated, the battery is full (100%-50%). No charging required.
- If the *yellow* LED is illuminated, the battery must be charged (50%-25%)
- If the *red* LED is illuminated, the battery must be charged (less than 25%). When you push a button, an audible signal will be emitted.

Service indication

- If the orange LED of the service display flashes, you must request a check of your bathing lift.

Overload

- If the orange LED of the overload flashes, the maximum weight is exceeded.

7.2 The keypad with/without scale

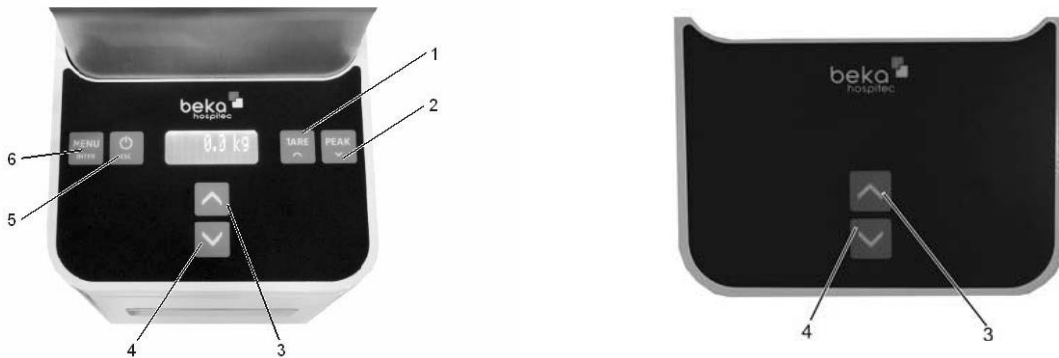

N°	Description	N°	Description
1	Taring	4	Lower lift
2	Peak	5	On/off switch/Quit menu
3	Raise lift	6	Confirm menu/input

The digital scale consists of a handset and a sensor. The scale is destined to measure weights. It is a non-calibrated scale. The following units can be set: kg and lb. With the EVE! persons up to 185 kg at the most can be weighed.

Button	Name in the measuring mode	Function in the measuring mode (grey font)	Name in the menu	Function in the menu (light blue font)
	ZERO POSITIONING / TARING	- Zero positioning/taring and - Clear peak values	up	- scroll up in the menu - increase numerical values
	PEAK	Toggle between displays: - of the current measured value - of the maximum value (= largest value in positive direction of force) - of the minimum value (= largest absolute value in negative direction of force)	down	- scroll down in the menu - decrease numerical values
	ON / OFF	Switch device on/off	escape	- exit submenu option during entry without saving - exit menu, return to measuring mode
	MENU	Open the menu	enter	- open selected menu option - confirm and save entry

7.2.1 Putting the scale into operation

Proceed in the following way to put the scale correctly into operation and to weigh a patient:

- Push the on/off button to switch the scale on.
- Wait for the scale to tare automatically to 0.0 kg or push the “Tare” button.
- Position the patient in the EVE! bathing and shower lift.

The correct weight of the patient is now displayed in 0.1 kg steps.

- Push the on/off button again to switch the scale off.

Make sure that the patient sits or lies completely in the bathing and shower lift. The weighing procedure must not be affected by the patient still resting in part on a chair/wheelchair/bed.

When calculating the weight, please observe that the proper weight of the clothes of the patient must be deduced from the displayed weight to determine the actual body weight.

7.2.2 Zeroing and taring the scale

Push the “Tare” button to set the digital scale to zero prior to a weighing procedure and without initial load. With this function, you can tare initial loads (sling, belt) as well. These initial loads must be correctly applied prior to the weighing and tarred by pushing the button.

7.3 The safety armrests

Both safety armrests can be folded back independently from one another. To fold the safety armrests back, you have to turn them backwards in end position as shown on the image (also refer to Chapter 15.6).



CAUTION



The safety armrests must not be used to support the patient when standing up from the lift.

7.4 The safety belt

The EVE! bathing and shower lift is equipped with a safety belt. The safety belt can be installed on either side of the arm supports! The most features 4 attachment points.

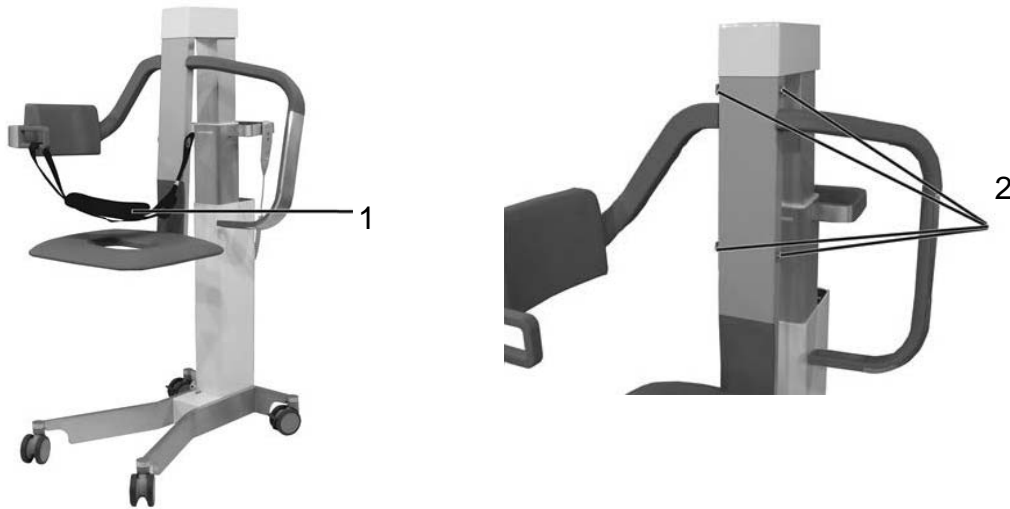





N°	Description	N°	Description
1	Safety belt	2	Attachment points

Use the top or bottom attachment point, depending on the body length of the patient.



Proceed in the following way to fasten the safety belt:

<p>Image 1: Pull the belt through the hole of the armrest</p>		<p>Image 2: Fasten the belt by snapping in the buckle</p>	
<p>Image 3: Suspend the belt in the corresponding attachment point.</p>		<p>Image 4: Pull on the belt to enlarge/reduce the belt size.</p>	

7.5 The control unit

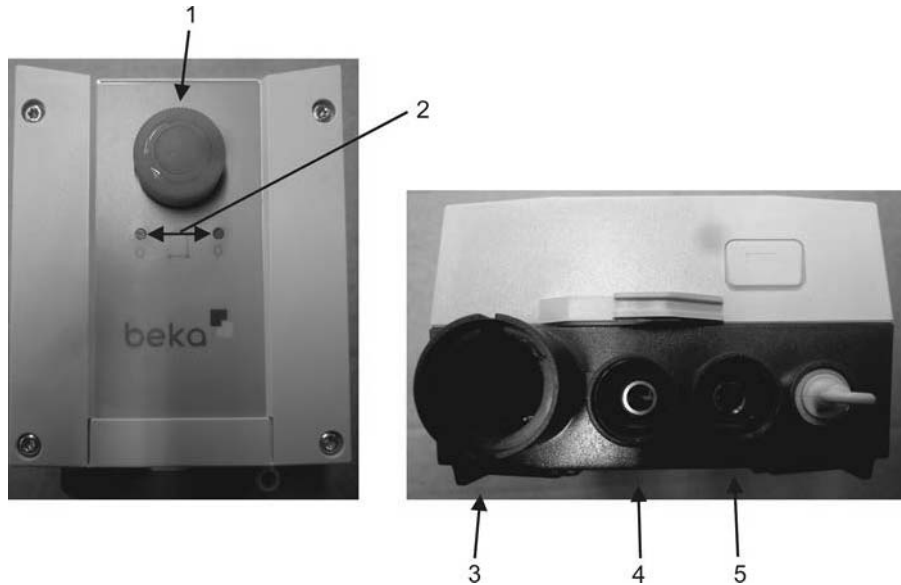

N°	Description	N°	Description
1	Emergency stop switch	4	Lifting motor connection
2	Electrical emergency lowering system (buttons for use in case of handset malfunction)	5	Not used
3	Handset connection		

7.5.1 Electrical emergency lowering system

Should your handset and the keypad be defective or missing or present a malfunction, and provided that the battery still has sufficient voltage, you can raise or lower the seat by means of the buttons located on the control unit.

Proceed in the following way to lower or raise the seat:

- Open the door of the control box and battery
- Push the emergency stop switch
- Insert a ballpoint or something similar in the corresponding button. In this way, the button is actuated

The seat is raised or lowered.

7.5.2 The emergency stop switch

By opening the door (of the control box and battery), the electric motor and the control unit are disconnected from the power supply. The motor stops immediately. This function represents the emergency stop function.

The emergency stop switch can also be used to reduce discharging of the battery in case of intermediate storage.

By opening the door, you can disable the EVE! bathing and shower lift, thus making any unauthorized use more difficult.

Close the door to re-enable the lift.



7.6 24V battery unit

The EVE! bathing and shower lift is equipped with a 24V battery. Proceed as described in Chapter 13.3 to remove the battery.



7.7 External charging unit/Wall charging unit

The external charging unit (wall charging unit) is a switch-mode charger and is supplied ready assembled (on a mounting rail). It can be installed on any suitable wall. The required power cable is included in the delivery. The charging time for the battery units is approx. 4 hours.



N°	Description	N°	Description
1	Mains operation indicator	3	Charging indicator
2	Cable holder (optionally)		

Display function of the charging unit

- If the green LED (ON) is illuminated, the control unit is supplied with voltage through the mains cable.
- If the yellow LED (CHARGE) is illuminated, the battery is being charged.

7.8 Crash protection

The EVE! bathing and shower lift is equipped with an automatic crash protection. If the product encounters an obstacle during the lowering procedure, the electric motor is automatically switched off. In this case, raise the lift and remove the obstacle. After that, you can use the lift as usual.

7.9 Automatic crushing protection

The EVE! bathing and shower lift integrates an automatic crushing protection. This protection is activated, when your fingers are between the protective cover and the column. If you have triggered the crushing protection, you must gently push on the top of the cover hood to reset it!



8. Operation

8.1 Prior to use

Conduct the following check once a day, however at least prior to each use of the bathing and shower lift, in order to ensure a safe and trouble-free operation:

- Visual check of the lift system (external damages and wear-and-tear)
- Functional check of the safety armrests
- Functional check of the handset and the keypad
- Test the electrical emergency lowering system
- Check the state of the battery
- Check whether the castors run free.

8.2 During use

The seat of the EVE! bathing and shower lift is raised and lowered by means of the supplied handset or the keypad.

Pushing the  button raises the seat.

Pushing the  button lowers the seat.

Please check that no obstacle is underneath the seat when the seat is moving.

The rear castors are equipped with parking brakes. Engage the castors when lifting a patient in order to avoid any unintentional and uncontrolled movement of the EVE! bathing and shower lift.

Travel path

When using the EVE! bathing and shower lift, make sure that the travel path of the bathing and shower lift is not narrowed by obstacles or other elements (e.g. wall racks, etc.). Remember also that the maximum height is limited to 1810 mm (without patient). Please take extreme care when passing through doors.

8.2.1 Lifting the patient from a bed

Please proceed in the following way to lift a patient from a bed:

- Approach the EVE! bathing and shower lift to the bed of the patient
- Fold back both safety armrests
- If necessary, lower the side rails of the patient's bed
- Turn the patient on his/her side
- Position the reclining surface or the seat of the EVE! bathing and shower lift over the mattress.
- Engage the castor brakes of the bathing and shower lift
- Now turn the patient onto the reclining surface/seat of the EVE!
- Fold the front armrest down, so that the patient can hold onto

- Help the patient adopting a sitting position; as soon as the patient is in sitting position, fold the rear armrest (with backrest cushion) down
- Fasten the safety belt
- Disengage the parking brakes of the castors
- Raise the lift until it can be moved away from the patient's bed
- Lower the lift to transport height

Now, you can drive the patient to the bath or shower facility.

8.2.2 Getting autonomously onto the seat lift

Proceed in the following way to enable the patient to get autonomously onto the lift:

- Engage the parking brakes
- Fold the safety armrests back
- Lead the patient to the seat of the EVE!
- Lower the backrest
- Position the patient on the seat with his/her back against the backrest
- Fold the safety armrest forward
- Secure the patient with the belt
- Push the arrow button  of the handset to raise the patient

Now, you can transport the patient.

Please observe the seat direction when transporting the patient!





9. Cleaning/Disinfection

9.1 Cleaning the EVE! bathing and shower lift

Clean the EVE! bathing and shower lift with a soft, lint-free cloth. For thorough cleaning, use a cloth moistened with a mild soap solution. Clean the product **every day and prior to each use**.

To avoid damages, no abrasive cleaners must be used to clean the handset and keypad control units.

<p>NOTE</p> 	<p>Make sure that the system is not in operation during the cleaning activities.</p>
<p>WARNING</p> 	<p>After each treatment, the EVE! bathing and shower lift must be completely disinfected with a disinfectant. In this way, any cross-contamination is avoided.</p>
<p>CAUTION</p> 	<p>Use disinfectants only when there is no patient in the bathing and shower lift. Strictly respect and observe the manufacturer's instructions for the used disinfectant. Avoid direct contact with the concentrated product. If necessary, use gloves and safety glasses to protect your skin and eyes.</p>

9.1.1 Cleaning the scale

Wipe down the scale with a damp cloth to clean it. Never use abrasive or corrosive cleaners.



9.2 Disinfecting the EVE! bathing and shower lift





With respect to risks of infection, you must disinfect your EVE! bathing and shower lift **every day and prior to each use**.

The EVE! bathing and shower lift can be wiped down for disinfection with the following products:

- Alcohol 70% (e.g. Mikrozyd AF liquid)
- Aldehyde (e.g. Antiseptica kombi)
- Oxygen releasers (e.g. Perform or Descogen liquid)

In order to be able disinfecting the bathing and shower lift, remove the padding in the following way:

<p>Image 1: Loosen the padding from the armrests.</p>		<p>Image 2: Remove the padding completely.</p>	
<p>Image 3: The image shows the armrests without padding.</p>			

<p>Image 1: Remove the padding by pulling.</p>		<p>Image 2: Proceed as shown in image 1.</p>	
<p>Image 3: Proceed as shown in image 1</p>		<p>Image 4: Remove the padding completely.</p>	

Re-assemble in reversed order!

9.3 Sterilizing the EVE! bathing and shower lift

The EVE! bathing and shower lift is **not** suitable for sterilisation.

10. Checks/tests

In order to ensure a safe use of our bathing and shower lift and the protection of the users and the patients, BEKA Hospitec prescribes an annual safety check.

We recommend a simultaneous maintenance of the device in order to conserve its full value.

The execution of the safety checks and maintenance must be documented and proven on request. Please use your inventory register to this effect.

The checks may only be conducted by the manufacturer either by specialists authorized by the manufacturer.

<p>NOTE</p> 	<p>In accordance with the UVV (accident prevention) regulations of the German employer's liability insurance association on mobile equipment which is used in special locations or installations, an annual check to the DGUV (German Statutory Accident Insurance Association) Prescription 3 (BGV A3) must be carried out on the EVE! bathing and shower lift.</p>
--	--

This check is only prescribed for Germany. In other countries, other requirements might be applicable.

<p>WARNING WORD</p> 	<p>Do not conduct any cleaning, maintenance or test activities when the bathing and shower lift is in use. This could cause danger to the user and the patient.</p>
--	---

Conduct a **weekly** visual inspection of all components, the power cable and all electrical connections. Conduct a functional test as well and clean the castors if necessary.

Conduct **every year** a maintenance, a safety check and DGUV prescription 3.

10.1 Maintenance of the 24 Volt battery

The battery and the control box must not be opened by the customer.

Repairs may be carried out only either by BEKA Hospitec or by companies authorized to this effect by BEKA Hospitec. If the battery is discharged, recharge it as soon as possible to extend the lifetime. Batteries stored in the warehouse/stock must be recharged every 6 months (a possible deep discharge may destroy the battery). The battery's lifetime basically depends on the charge (number of lifting cycles) and the charging state. It can be up to 5 years. Have defective or worn out batteries, and defective charging units in general, replaced.

11. Waste disposal

11.1 Disposal of the packaging material

Please recycle the packaging materials of the EVE! bathing and shower lift in accordance with the locally applicable regulations and laws.

11.2 Disposal of the product

At the end of the product's lifetime, contact your BEKA dealer, who will recycle the EVE! bathing and shower lift in accordance with the locally applicable regulations and laws.

For an environmentally-sound disposal, the company BEKA Hospitec GmbH will provide more information in its capacity of manufacturer.

Please clean and disinfect the EVE! bathing and shower lift prior to its disposal as well.

12. Troubleshooting/After-sales service

12.1 Troubleshooting help

Problems with the lift	Remedy
Stroke adjustment of the lift not operating.	<ul style="list-style-type: none"> a) Check if the emergency stop switch is actuated (door must be closed!). b) Check that the cables of the control box are correctly connected. c) Check the battery's state of charge. d) Remove the battery pack and check the contacts for damage.
The lift remains in the top end position.	<ul style="list-style-type: none"> a) Check if the emergency stop switch is actuated (door must be closed!). b) Check the battery's state of charge. c) Use the electrical emergency lowering feature (see 7.7) to lower the patient/resident.
The drive stops during the lifting procedure.	<ul style="list-style-type: none"> a) Battery low. Charging/Replacing the battery. b) The maximum load is exceeded (max. patient weight).
The drive stops during the lowering process.	<ul style="list-style-type: none"> a) Battery low. Charging/Replacing the battery. b) An obstacle is located below the seat. In this case, raise the lift and remove the obstacle.
The control box emits a "beep" signal when operated.	Battery low. Charge the battery.
The handset does not work.	<ul style="list-style-type: none"> a) Check the connector located on the carrier frame. You will find the connector behind the cover plate. b) Check the battery's charging state (replace with fully charged battery).
The up and down buttons of the handset do not respond.	<ul style="list-style-type: none"> a) Check if the emergency stop switch is actuated (door must be closed!). b) Check the battery's charging state (replace with fully charged battery). c) Check that the cables of the control box are correctly connected.
The castors produce loud noises.	Clean castors if necessary. Replace if necessary.
The bathing and shower lift produces unusual noises.	Inform the after-sales service.
The bathing and shower lift shows signs of damage.	Inform the after-sales service.
The "Service" indication is lit.	The annual safety check must be carried out.

One armrest is lower than the other one	The armrest is misaligned. Re-align the armrest by means of a hexagonal wrench (cf. Chapter 15.6)
Problems with the charging unit	Remedy
The charging unit does not work.	a) Remove the battery pack and check the contacts for damage. b) Check the mains plug.
The operating display of the charging unit is not lit.	a) Check that the charging unit is connected to a power outlet. b) Check the power outlet fuse.
The charging unit is connected to the power outlet, but the operating display is not lit.	a) Check that the wall outlet is supplied with power. b) Remove the battery and check for damage.
Problems with the battery	Remedy
The battery is placed correctly, but the indicator lights are not lit.	Inform the after-sales service.
The indicator light does not go out after multiple hours of charging.	The battery must be replaced. Inform the after-sales service.
The battery installed in the charging unit indicates that it is fully charged. However, when placed in the sling hoist, just a few lifting cycles are possible.	The battery must be replaced. Inform the after-sales service.
When the handset is actuated, an acoustic signal is emitted and the indicator light (red) is on.	Check the battery's charging state.

When your EVE! bathing and shower lift does not function properly and you cannot eliminate the error by means of the remedies listed in paragraph 13, please contact the customer service of your dealer either the manufacturer.

	<p>BEKA Hospitec GmbH Am Rübenmorgen 3 35582 Wetzlar Phone: +49(0)641-9 22 22-0 Fax: +49(0)641-9 22-22-20 info@beka-hospitec.de</p>
---	--

13. Assembly/Disassembly

13.1 Replacing the castors

Image 1:

Required tools:

1 hexagonal wrench size
10



Image 2:

Loosen the screw
with the hexagonal
wrench.



Image 3:

Loosen the castor from the
carrier frame.



Re-assemble in reversed order!

13.2 Replacing the handset

Image 1:

The image shows the
cover plate.



Image 2:

Remove the cover
plate by pulling.



Image 3:

Remove the handset.



Image 4:

Plug in a new
handset.



Image 5:

Stow the connector in
the tin box.



Image 6:

Re-install the cover
plate.



13.3 Replacing the battery

Image 1:
The image shows the inserted battery.



Image 2:
Unlock the battery by means of the release lever in the battery handle.



Image 3:
Pull the battery up to remove it.



Image 4:
The image shows the opened control box without battery.



When re-installing the battery, make sure that the tripping lever engages audibly.

13.4 Replacing the control unit

Image 1:
Required tools:
1 hexagonal wrench
size 4



Image 2:
Lift the battery out of the control box (as described in 15.4)



Image 3:
Remove the motor cable from the control unit.



Image 4:
Unplug the cable of the handset from the control unit.



Image 5:
Loosen the top screw of the mounting bracket.

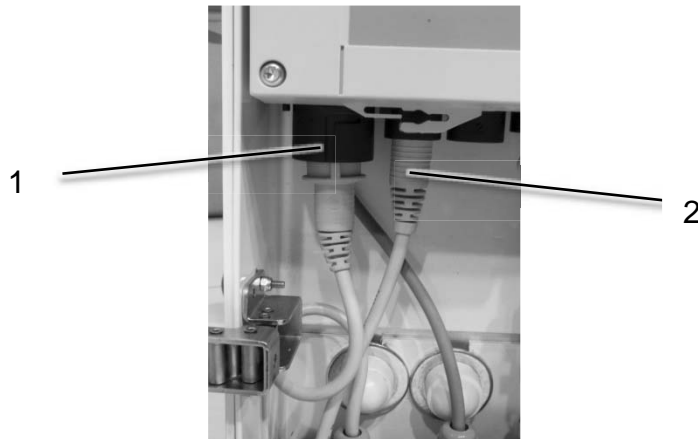

Image 6:
Loosen the bottom screw of the mounting bracket.



Now, you can remove the control unit.

Re-assemble in reversed order.



N°	Description	N°	Description
1	Cable of the handset	2	Hoist motor:

When assembling the control unit, make sure to assign the motor cable and the handset cable in the following way.

The cable of the handset must engage.

13.5 Positioning the armrests

13.5.1 Setting the angle of the armrests

Image 1:

Required tools:

1 hexagonal wrench
size 5



Image 2:

Turn the screw with
the hexagonal
wrench and set the
desired angle.



13.5.2 Disassembling the armrests

Image 1:

Required tools:

1 ratchet with
extension and nut 17



Image 2:

Remove the
protective cover.



Image 3:
The image shows the two screws for the armrests.



Image 4:
Put the ratchet on the screw and turn it counter clockwise to loosen the armrest.

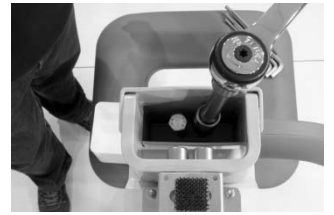

Image 6:
Now, you can move the armrest.



Image 7:
Fold the armrest back until it disengages from its latching.



Image 8:
Pull out the armrest.



When installing the protective cover, make sure that the Velcro fasteners are positioned on top of each other!

Re-assemble in reversed order.

14. Appendix

14.1 Technical data

Dimensions and weights

- Length arm opened:	94.0 cm
- Length arm closed:	95.0 cm
- Width:	68.0 cm
- Height:	124 cm
- Seat height min.:	49.5 cm
- Seat height max.:	106.5 cm
- Accuracy of the scale:	200 grams
- Weight without packaging:	approx. 63 kg
- Turning radius:	R= 110.0 cm
- Safe Working Load (SWL):	max. 185 kg

Electrical data

Control unit/Charging unit

- Protection class:	Class II
- Applied part:	Type B
- Operating mode:	Short-term operation
- Input voltage:	100 V - 240 V~ (AC) / 50 / 60 Hz
- Output voltage:	24 V (DC)
- Power consumption	I in max. 1 Amp. / I out max. 10 Amp.

Spindle motor

- Operating mode:	Short-term operation
- Input voltage:	24 V (DC)
- Power consumption	I in max. 7 Amp
- Protection class:	IP X4
- Duration of treatment:	2 min. continuous operation followed by 18 min. pause

Ambient conditions

Operation

- Temperature range:	10° C to 40° C
----------------------	----------------

- Relative humidity: 30% to 75%, non-condensing

- Atmospheric pressure: 800 – 1060 hPA

Storage and transport

- Temperature range (stand-up and raising aid): -40° C to 70° C

- Temperature range (battery): -15° C to 40° C

- Relative humidity: 10% to 80%, non-condensing

- Atmospheric pressure: 500 – 1100 hPA

14.2 Design drawing

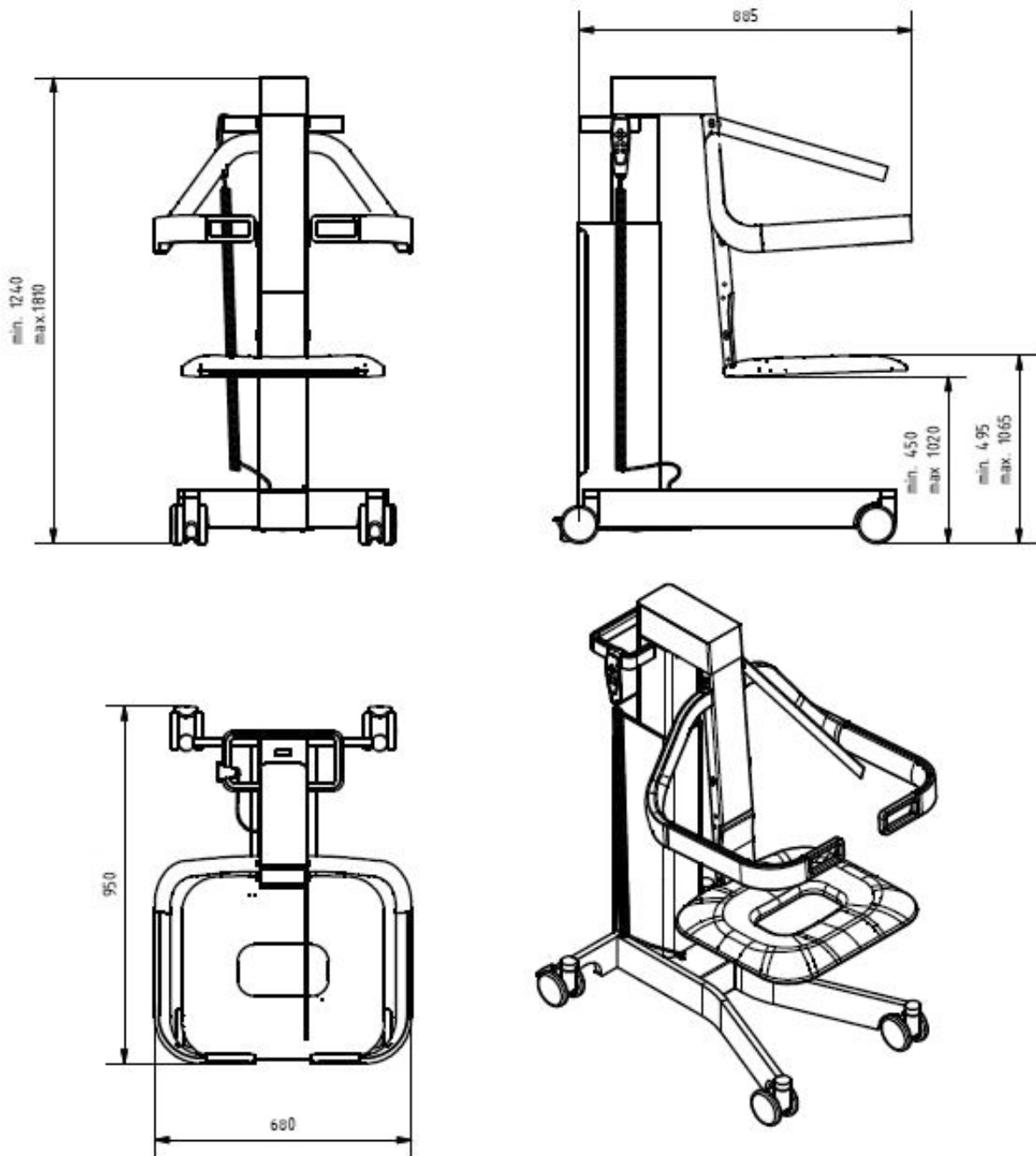

turning radius

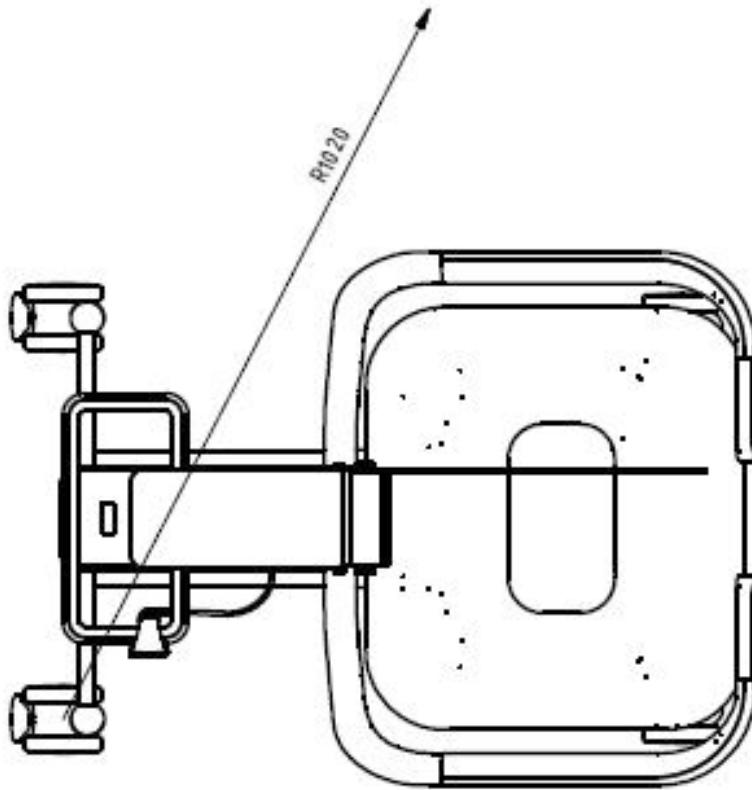

14.3 Declaration of Conformity



EG-Konformitätserklärung / EC-Declaration of Conformity

Der Hersteller / *The manufacturer*

BEKA Hospitec GmbH
Am Rübenmorgen 3
D-35582 Wetzlar-Dutenhofen

erklärt in alleiniger Verantwortung gemäß EG-Richtlinie für Medizinprodukte 93/42/EWG Annex VII,
 dass die folgenden Produkte
declares under sole responsibility according to the EU Medical Device Directive 93/42/EEC, Annex VII that
the following products

EVE!	Artikel Nr. P/N.	920107000 / 920108000
ADAM!	Artikel Nr. P/N.	920109000 / 920109500

den grundlegenden Anforderungen entsprechen und die Voraussetzungen für die CE-Kennzeichnung erfüllen.
comply with the essential requirements and fulfill the provisions of CE marking.

Die Bauart der Produkte entspricht Klasse I des Medizinproduktegesetzes (MPG), Regel 12.
The products correspond with Class I Medical Device Directive (MDD), Rule 12.

Zur Beurteilung wurden folgende Normen / Richtlinien herangezogen:
The following standards / directives apply:

EG-Richtlinie 93/42/EWG/ Directive 93/42/EEC		DIN EN ISO 14971:2013
DIN EN 10535:2007		DIN EN 60601-1:2007
DIN EN 12182:2012		DIN EN 60601-1-2:2007

Diese Erklärung trifft auf alle Produkte zu, die nach Ausstellung dieser Erklärung produziert wurden, bis sie
 durch eine andere Erklärung ersetzt wird.
This declaration applies to all CE marked devices manufactured from the date of its issuance on until it is
either superseded by another declaration or withdrawn.

Technische Änderungen vorbehalten / *Technical changes reserved.*

Wetzlar, den 04.07.2017

 Robert Deschler
 Geschäftsführer

BEKA Hospitec GmbH
 Am Rübenmorgen 3
 D-35582 Wetzlar-Dutenhofen
 Fon 0641 / 92 22 0-0
 Fax 0641 / 92 22 0-20

USt-IdNr.: DE278603356
 Amtsgericht Wetzlar, HRB 6207
 info@beka-hospitec.de
 www.beka-hospitec.de

Geschäftsführung
 James Stuart-Smith
 Robert Deschler

Commerzbank AG Wetzlar
 Konto-Nr.: 482176500
 BLZ: 515 400 37
 IBAN: DE60515400370482176500
 SWIFT-BIC: COBADEFF515

14.4 Accessories/Spare parts

Bathing and shower lift	Article number
EVE! incl. wall charging unit	920107000
EVE! with digital scale incl. wall charging unit	920108000
Supplement for the subsequent installation of a digital scale	920107500
Spare battery 24V	921070602
Wall charging unit (grey)	921070702
Flat-rate freight charge/toll	500001000

Spare part n°	Description
Z9200840	Seat cushion
Z9200849	Right-hand side armrest coating
Z9200850	Left-hand side armrest coating
Z9200843	Manoeuvring handle
Z9200858	Back cushion

Drawing/development n°	Castors	Quantity
NE050902	Castors (rear with brake)	Quantity: 1
NE050903	Castors (front)	Quantity: 1

14.5 Electromagnetic Compatibility

Electrical medical equipment is subject to special precautionary measures with regard to EMC and must be installed and operated in accordance with the EMC instructions included in the accompanying documents.

For the devices and systems from BEKA Hospitec GmbH, no special measures must be observed.

Portable and mobile HF-communications equipment can interfere with electrical medical equipment.

Guidance and manufacturer's declaration - electromagnetic immunity (Table 201)		
The EVE! been designed for use in the hereafter listed ELECTROMAGNETIC ENVIRONMENTS. The customer or the user of the EVE! must ensure that the appliance is used in such environment.		
Emission measurements	Compliance	Electromagnetic environment - guidelines
High-frequency (HF) emissions to CISPR 11	Group 1	The EVE! uses HF radiation exclusively for internal functions. Therefore, the HF radiation of the device is very low and any interference with adjacent electrical equipment is unlikely.
High-frequency (HF) emissions to CISPR 11	Class B	The EVE! is intended for use in any type of facility including living quarters and those that are directly connected to a public mains network that supplies residential buildings and buildings used for domestic purposes.
Harmonics to IEC 61000-3-2	Class A	
Voltage fluctuations/ flicker to IEC 61000-3-3	Compliant	

Guidance and manufacturer's declaration - electromagnetic immunity (Table 202)			
The EVE! been designed for use in the hereafter listed ELECTROMAGNETIC ENVIRONMENTS. The customer or the user of the EVE! must ensure that the appliance is used in such environment.			
Immunity testing	IEC 60601- Test level	Compliance level	Electromagnetic environment guidance
Discharging of static electricity (ESD) to IEC 61000-4-2	± 6kV contact discharge ± 8kV air discharge	± 6kV contact discharge ± 8kV air discharge	The floor must be in wood, concrete or ceramic tiles. In case of floors in synthetic material, the relevant air humidity must be at least 30%.
Rapid transient interference pulses/burst IEC 61000-4-4	± 2 kV for power supply cables ± 1 kV for	± 2 kV for power supply cables not applicable to input/	The quality of the supply voltage should match

	input/ output cables	output cables	that of a typical business or hospital environment.
Overvoltage IEC 61000-4-5	±1 kV cable against cable ±2 kV cable against ground connection	±1 kV cable against cable ±2 kV cable against ground connection	The quality of the supply voltage should match that of a typical business or hospital environment.
Voltage drops, short interruptions and voltage fluctuations in the power supply input cables IEC 61000-4-11	<5 % U_T (>95 % drop of U_T) for 0.5 period <40 % U_T (>60 % drop of U_T) for 5 periods <70 % U_T (>30 % drop of U_T) for 25 periods <5 % U_T (>95 % drop of U_T) for 5 s	<5 % U_T (>95 % drop of U_T) for 0.5 period <40 % U_T (>60 % drop of U_T) for 5 periods <70 % U_T (>30 % drop of U_T) for 25 periods <5 % U_T (>95 % drop of U_T) for 5s	The quality of the supply voltage should match that of a typical business or hospital environment.
Current frequency (50/60 Hz) Magnetic field IEC 61000-4-8	3 A/m	3 A/m	Power frequency magnetic fields should be at levels characteristic of a typical location in a typical business or hospital environment.

CAUTION U_T is the mains AC voltage before the application of the test level.

Guidance and manufacturer's declaration - electromagnetic immunity (Table 204)

The EVE! has been designed for use in the hereafter listed electromagnetic environments. The customer or the user of the EVE! must ensure that the product is used in such environment.

Immunity testing	IEC 60601- Test level	Compliance level	Electromagnetic environment guidance
Conducted HF IEC 61000-4-6	3 Vrms 150 kHz up to 80 MHz	10 Vrms	Portable and mobile HF communications equipment should be used no closer to any part of the EVE! including cables, than the recommended separation distance calculated in accordance with the equation applicable to the

<p>Radiation HF IEC 61000-4-3</p>	<p>3 V/m 80 MHz up to 2.5 GHz</p>	<p>3 V/m</p>	<p>frequency of the transmitter.</p> <p>Recommended separation distance d=0.35VP</p> <p>d=1.2VP 80 MHz up to 800 MHz</p> <p>d=2.3VP 800 MHz up to 2.5 GHz</p> <p>With <i>P</i> as the rated output of the transmitter in Watt (W) in accordance with the manufacturer's specifications and <i>d</i> as the recommended separation distance in meter (m).</p> <p>The field strength of fixed HF-transmitters as determined by an electromagnetic field survey,^a – should be less than the COMPLIANCE LEVEL in each frequency range.^b</p> <p>In the vicinity of equipment marked with the following symbol, interference may occur:</p> 
---------------------------------------	---	--------------	---

NOTE 1: At 80 MHz and 800 MHz, the higher frequency range applies.

NOTE 2: This manual could possibly not apply to all situations. Electromagnetic propagation is affected by absorption and reflection from structures, objects and people.

^a The field strength of fixed RF transmitters, such as base stations of mobile phones and land mobile radios, amateur radio stations, AM and FM radios as well as radio and television broadcast media cannot be predicted theoretically with accuracy. To assess the electromagnetic environment due to fixed RF transmitters, an electromagnetic site survey is recommended. If the field strength measured in the environment where the EVE! is to be used, exceeds the applicable HF compliance level, special care should be taken that a normal operation of the EVE! can be guaranteed. In case anomalies are identified, additional measures could be required, such as a different alignment or a change of the location of the EVE!

^b In the frequency range from 150 kHz to 80 MHz, the field strength must be less than 10 V/m.

**Recommended distance between portable and mobile communications equipment and the EVE!
(Table 206)**

The EVE! is intended for use in an electromagnetic environment with controlled HF interferences. The customer or the user of the EVE! can avoid electromagnetic interference by respecting and observing the minimum distance between portable and mobile HF telecommunication devices (transmitters) and the EVE! depending on the rated output of the communication device as specified below.

<p>Rated output of the transmitter</p>	<p>Separation distance depending on the transmitting frequency in m</p>
---	--

W	150 kHz to 800 MHz $d=0.35\sqrt{P}$	80 MHz to 800 MHz $d=1.2\sqrt{P}$	800 MHz to 2.5 GHz $d=2.3\sqrt{P}$
0.01	0.04	0.12	0.23
0.1	0.11	0.38	0.73
1	0.35	1.2	2.3
10	1.1	3.8	7.3
100	3.5	12	23

For transmitters rated at a maximum output power not listed above, the recommended separation distance d in meters (m) can be determined using the equation applicable to the frequency of the transmitter, where P is the maximum output power rating of the transmitter in watts (W) according to the specifications given by the transmitter manufacturer.

NOTE 1: At 80 MHz and 800 MHz, the separation distance for the higher frequency range applies.

NOTE 2: These guidelines could not apply to all situations. Electromagnetic propagation is affected by absorption and reflection from structures, objects and people.

14.6 Journal

According to §8 of the Medical Device Directive, you are compelled to keep a journal for this device. You can use this journal as template.

Journal

Device: Bathing and shower lift EVE!

Manufacturer: BEKA Hospitec GmbH, Am Rübenmorgen 3, 35582 Wetzlar

Serial number: _____

Date of purchase: _____

Site: _____

Checks and inspection conducted upon the first use:

Date: _____

Evidence of the training session on the functions and the use of the EVE!

Instructor		Trained person	
Name	Date	Name	Signature

